

LONG RANGE LED LANTERN

GML

up to 17 NM+

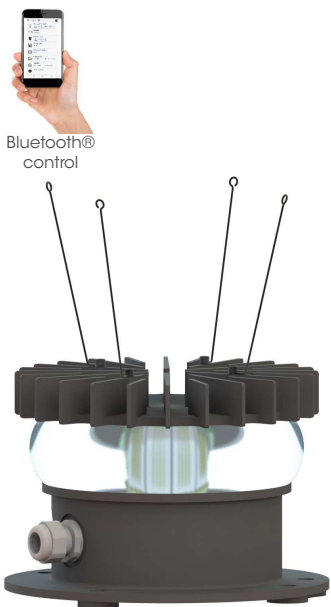

Bluetooth® control

The GML is a very efficient long range LED lantern, ideal to be used as coastal light. It can achieve a range up to 17 NM+, depending on color and number of tiers.

Benefits include :

- High performances
- Low consumption
- Quick set up and easy to use with GISMAN Bluetooth® application
- Optional A2NGO monitoring cybersecured system
- Optional AIS Transponder
- 3 years warranty
- Service life over 10 years
- IALA compliance to applicable recommendations

Technical Features

- Vertical divergence : 2.5° @ 50%
- Colors: white, red, green and yellow for GML-1T white for GML-2T and GML-3T
- Programmable flash characters: 369 + 1 personalized
- Allard correction for short flash characters
- Adjustable range
- Adjustable ambient light levels
- Bluetooth® programming and communication module

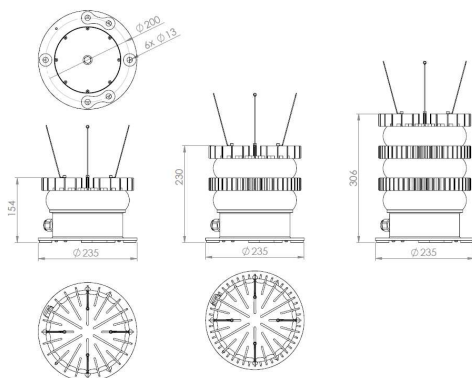

1 Tier (1T)

2 Tiers (2T)

3 Tiers (3T)

OPTICAL PERFORMANCES

GML-1T	White	Red	Green	Yellow
Intensity I _{max} (Cd)	12 000	10 200	10 200	4 700
Range (NM) @0.74T	14.6	14.3	14.3	12.5
Range (NM) @0.85T	23.2	22.5	22.5	19.3

GML-2T	White	GML-3T	White
Intensity I _{max} (Cd)	24 000	Intensity I _{max} (Cd)	36 000
Range (NM) @0.74T	16.2	Range (NM) @0.74T	17.2
Range (NM) @0.85T	26.2	Range (NM) @0.85T	28

MATERIALS

Lens: acrylic (PPMA)
Lantern body: anodized aluminium - UV stabilized
Heat exchanger: anodized aluminium

GML SUPPLY VOLTAGE

12V or 24V for 1T, 24V for 2T and 3T.

CERTIFICATION AND TESTS

European Community: Pending
IALA: R0201 compliance of the colors
ISO Certification 9001-2015
Ingress protection: IP 68 - IEC 60529
Cybersecurity: NIST 800
Vibration: MIL STD 202G
Shock: MIL STD 202G
Thermal shock: IEC 60945
Salt fog: IEC 60945

WEIGHT

GML-1T : 3.3 kg - GML-2T: 5.2 kg - GML-3T: 7.2 kg

MOUNTING

3 or 4 screws M10 on Ø200mm

TEMPERATURES RANGE

From - 40 °C/-40 °F to + 65 °C/149 °F

Available options



GPS synchronization



Default light alarm output or AIS connectivity

Monitoring Communication options (external)



Satellite



GSM



SIGFOX

AIS Transponder options (external)



AIS Type 1



AIS Type 3

How to order your lantern?

Compose your order code in only 5 steps, which will look like: GML-[V]-2D5-[C]-[OPT]-[MONIT]-[AIS]

1. Type the lantern **version**: GML-1T or GML-2T or GML-3T
2. Choose the **color** of the light for GML-1T: W (White), R (Red), G (Green) or Y (Yellow). For GML-2T and 3T, it will only be W (White).
3. Select one or more of the available **options**:
- GPS: GS
- Alarm: AL or ALAIS
4. Choose one **monitoring communication option**: SAT (Satellite), GSM (GSM) or SIGFOX (SigFox).
5. Choose the **AIS transponder option**: type 1 (AIST1) or type 3 (AIST3).

Order code example: GML-1T-2D5-W-GS

You get your order code! You can place your order by email to support@gisman.fr or by phone.